

**INSTRUCTIONS FOR INSTALLING A 5 COUNT, 7 COUNT OR 9 COUNT MODULE CONVERSION KIT IN A NATIONAL VENDORS<sup>®</sup>, CROWN SEVENTY TWO<sup>®</sup> GG-424 GRAND GOURMET FOOD MERCHANDISER**

**CHECK THE PARTS RECEIVED IN THE KIT WITH THE PARTS LIST IN THESE INSTRUCTIONS. IF ANY PARTS ARE MISSING, CONTACT NATIONAL VENDORS' PARTS DEPARTMENT IMMEDIATELY.**

These instructions cover the procedure for installing a 5, 7 or 9 Count Module Conversion kit in a GG-424 Grand Gourmet Food Merchandiser.

Read these instructions carefully and thoroughly before installing the kit. Retain these instructions for part number and installation information.

5 Count Module Conversion kit, part number 424-7546, contains the following parts:

Part Number	Description	Quantity
424-7502	6 in. Idler Gear	1
424-7532	5 Capacity Belt Assembly	1
424-7548	5 Count Adapter Washer	1
424-7545	Installation Instructions * * *	1

7 Count Module Conversion Kit, part number 424-7706, contains the following parts:

Part Number	Description	Quantity
424-7702	4 in. Idler Gear	1
424-7705	7 Capacity Belt Assembly	1
424-7504	Belt Divider	5
424-7704	Rear Blocker	1
424-7707	7 Count Adapter Washer	1
424-7545	Installation Instructions * * *	1

9 Count Module Conversion Kit, part number 424-7905, contains the following parts:

Part Number	Description	Quantity
424-7902	3 in. Idler Gear	1
424-7904	9 Capacity Belt Assembly	1
424-7504	Belt Divider	10
424-7704	Rear Blocker	1
424-7906	9 Count Adapter Washer	1
424-7545	Installation Instructions * * *	1

**NOTE**

*To improve Module performance and durability, National Vendors recommends that early and intermediate production type Module Assemblies (see "Note" following Step A-8 of these instructions) be upgraded to the latest design Module Assembly. To upgrade a Module order Module Upgrading Kit, part number 424-7543, from National Vendors Parts Department.*

**TO INSTALL THE KIT**

**A. PARTS REMOVAL**

1. Remove the Forward Sprocket Gear from the Module Assembly to be converted. See Figure 1.
2. Compress both of the Rear Spring Loads on the Module, as shown in Figure 1, and rest them against the Plastic Studs on either side of the Module.
3. Fold back one of the Belt Dividers near the front of the Module. See Figure 1.
4. Grasp the Product Belt to the front and rear of the folded Belt Divider and push the Belt together as shown in Figure 2.
5. Pull the Front Section of the Product Belt up and towards yourself. The Product Belt will come apart. See Figure 2.
6. Remove the Belt Divider.

**CAUTION**

**Always pull the Belts in a Forward direction; on the top side, from the rear of the Module to the front.**

**Never pull the Belts backwards; from the front of the Module to the rear. Pulling the Belts backwards can break the Belt Dividers.**

7. Place the palm of your hand on the front section of the Belt as shown in Figure 3 to guide the Belt through the Module, and pull forward on the back section of the Belt to remove it from the Module.

CRANE

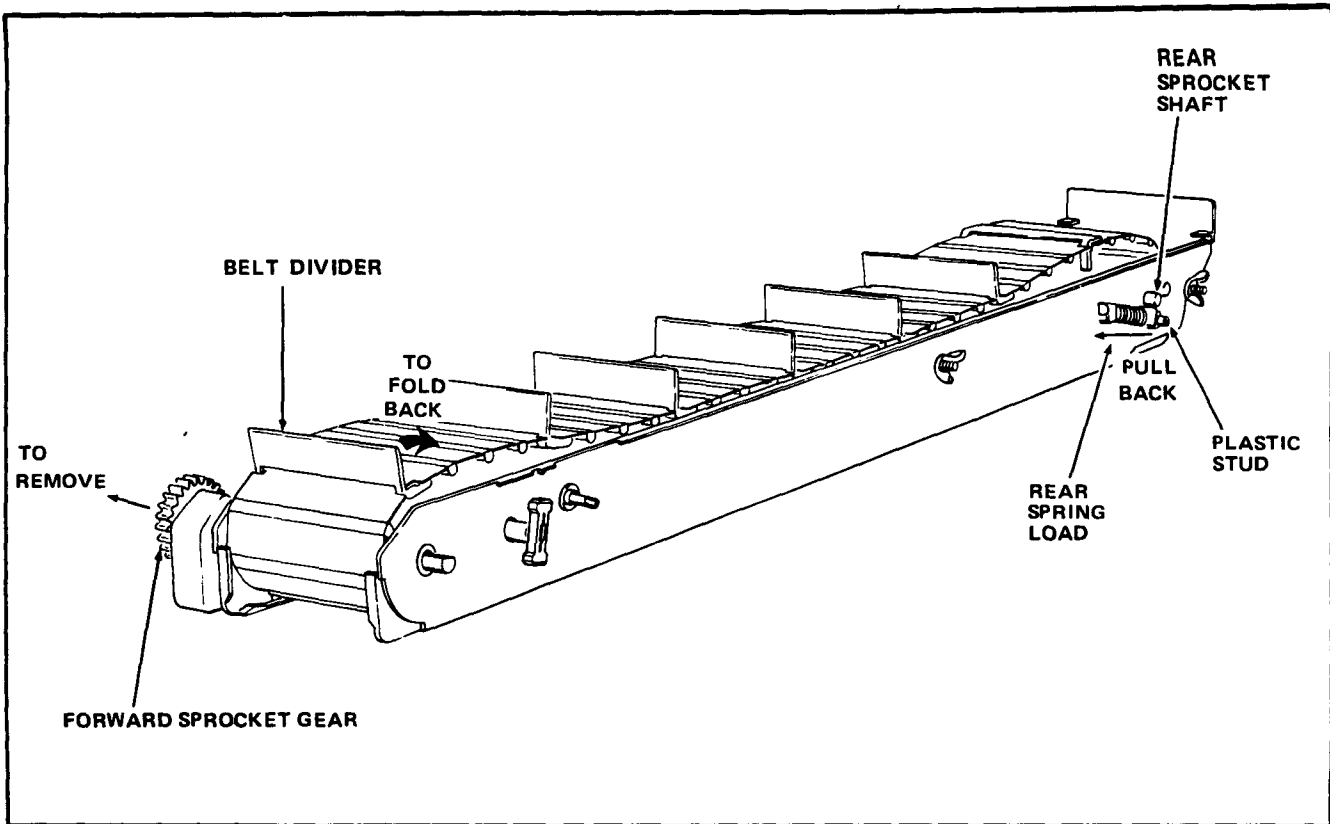

FIGURE 1

8. Remove all remaining Belt Dividers from the Product Belt.

**NOTE**

Three types of Module Assemblies have been produced:

1. An early production Module Assembly equipped with a short Idler Gear Shaft and Idler Gear Shaft Locator. (See Figure 4).
2. An intermediate production Module Assembly equipped with a short Idler Gear shaft and an Adapter Washer. (See Figure 5).
3. A late production Module Assembly equipped with a long, thru-module Idler Gear Shaft, an Idler Gear Bushing and an Adapter Washer. (See Figure 6).

Step A-9 applies only to the early production type Module Assembly. Step A-10 applies only to the intermediate production type Module Assembly. Steps A-11 through A-14 apply only to the late production type Module Assembly.

9. Remove the Idler Gear Shaft, Idler Gear, Idler Gear Shaft Locator, Idler Gear Shaft Washer and one attaching Nut from the Module Assembly. See Figure 4.
10. Remove the Idler Gear Shaft, Idler Gear, Adapter Washer, Idler Gear Shaft Washer and one attaching Nut from the Module Assembly. See Figure 5.

11. Remove one attaching Nut, the Idler Gear Bushing, Idler Gear and Adapter Washer from the Module Assembly. See Figure 6.
12. Remove the Slotted Driveshaft Coupling from the Driveshaft. See Figure 6.
13. Remove three attaching Wing Nuts and the Right Side Rail from the Module Assembly. See Figure 6.
14. Pull the Idler Gear Shaft out of the mounting hole in the Left Side Rail. Be sure to retain the Idler Gear Washer located on the Shaft. See Figure 6.

**B. INSTALLATION OF THE KIT**

**NOTE**

1. Step B-1 applies only to converting an early production type Module Assembly. Steps B-2 and B-3 apply only to converting an intermediate production type Module Assembly. Steps B-4 through B-8 apply only to converting a late production type Module Assembly.
2. On intermediate and late production Module Assemblies, each position of the three-position Idler Gear Mounting Hole (See Figure 5 or 6) is identified with either a 5, 7 or 9, denoting the position to be selected for a 5 Count, 7 Count or 9 Count Module Assembly.

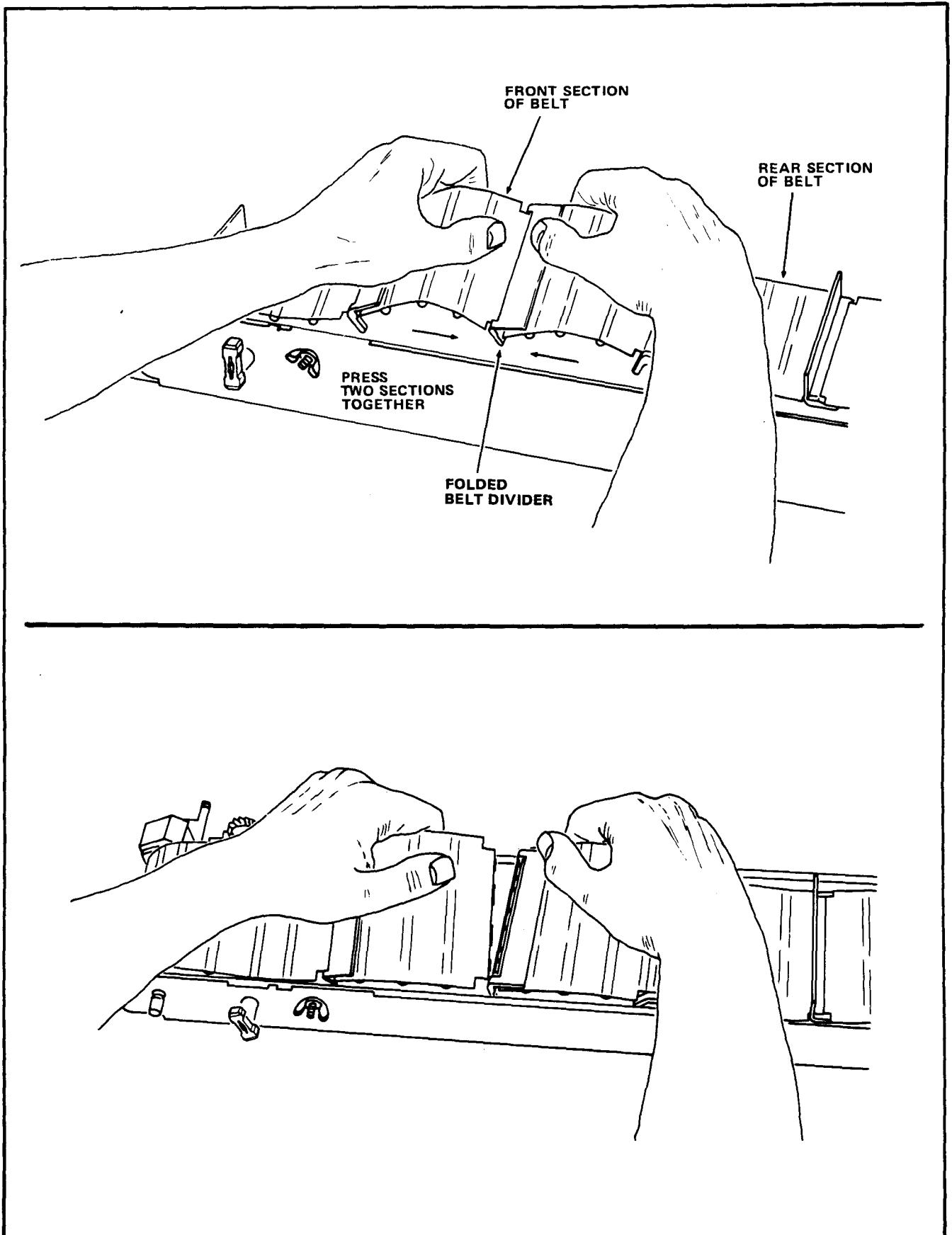

FIGURE 2

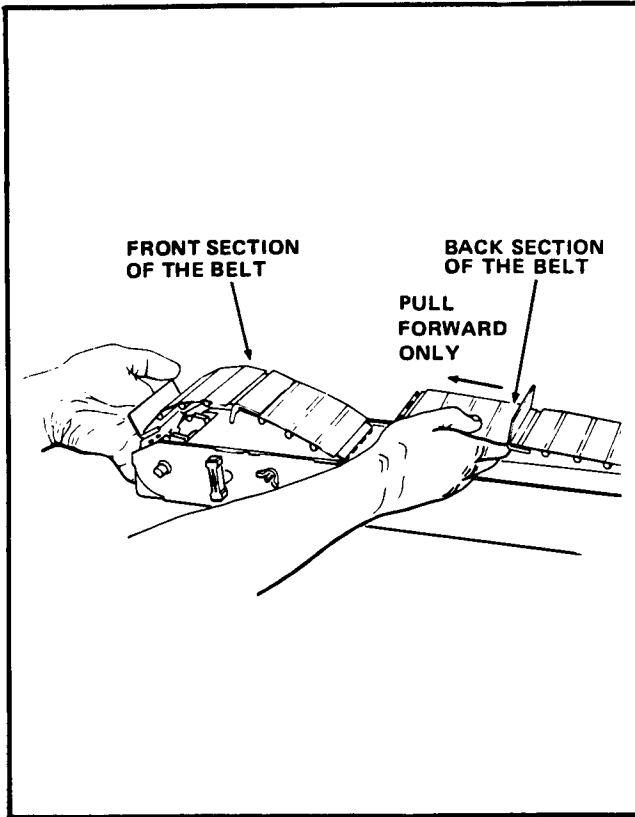

FIGURE 3

1. Install in the Module Assembly the replacement Idler Gear included in the kit, along with the Idler Gear Shaft, Idler Gear Shaft Locator, Idler Gear Shaft Washer and the attaching Nut removed in Step A-9. Make sure that the Idler Gear Shaft is located so that the inner portion of the replacement Idler Gear meshes with the Gear on the Module Driveshaft Assembly. See Figure 4.
2. Fit the replacement Adapter Washer included in the kit into the depression surrounding the Idler Gear Mounting Hole, aligning the hole in the Adapter Washer with the appropriate position (5, 7 or 9) of the three-position Idler Gear Mounting Hole. See Figure 5.
3. Install in the Module Assembly the replacement Idler Gear included in the kit, along with the Idler Gear Shaft, Idler Gear Shaft Washer and attaching Nut removed in Step A-10. See Figure 5.
4. With the Idler Gear Washer in place on the Idler Gear Shaft, insert the threaded end of the Idler Gear Shaft through the appropriate position (5, 7 or 9) of the three-position Idler Gear Mounting Hole. The Idler Gear Washer should be resting flush against the inside of the Left Side Rail and the Idler Gear Shaft should be inserted through the slots in both Shaft Spacers. See Figure 6.

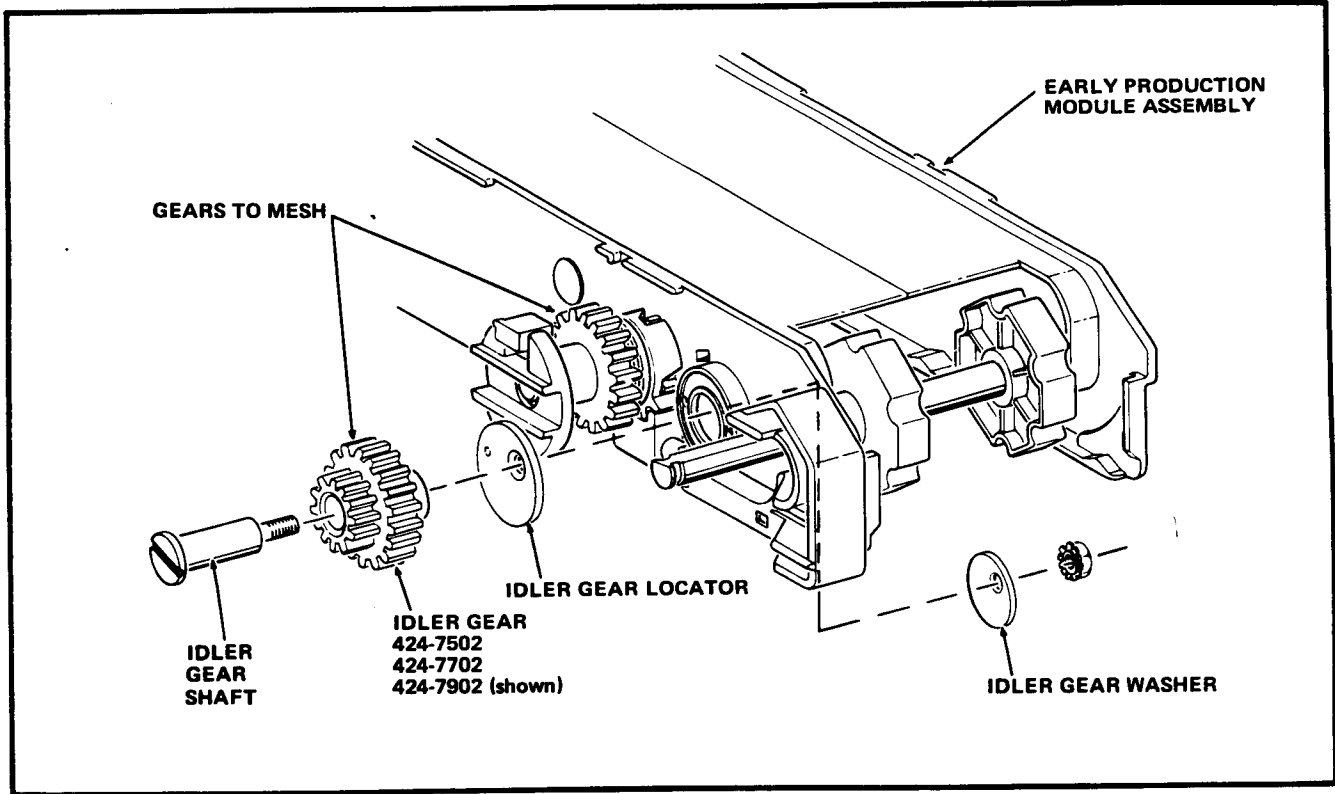
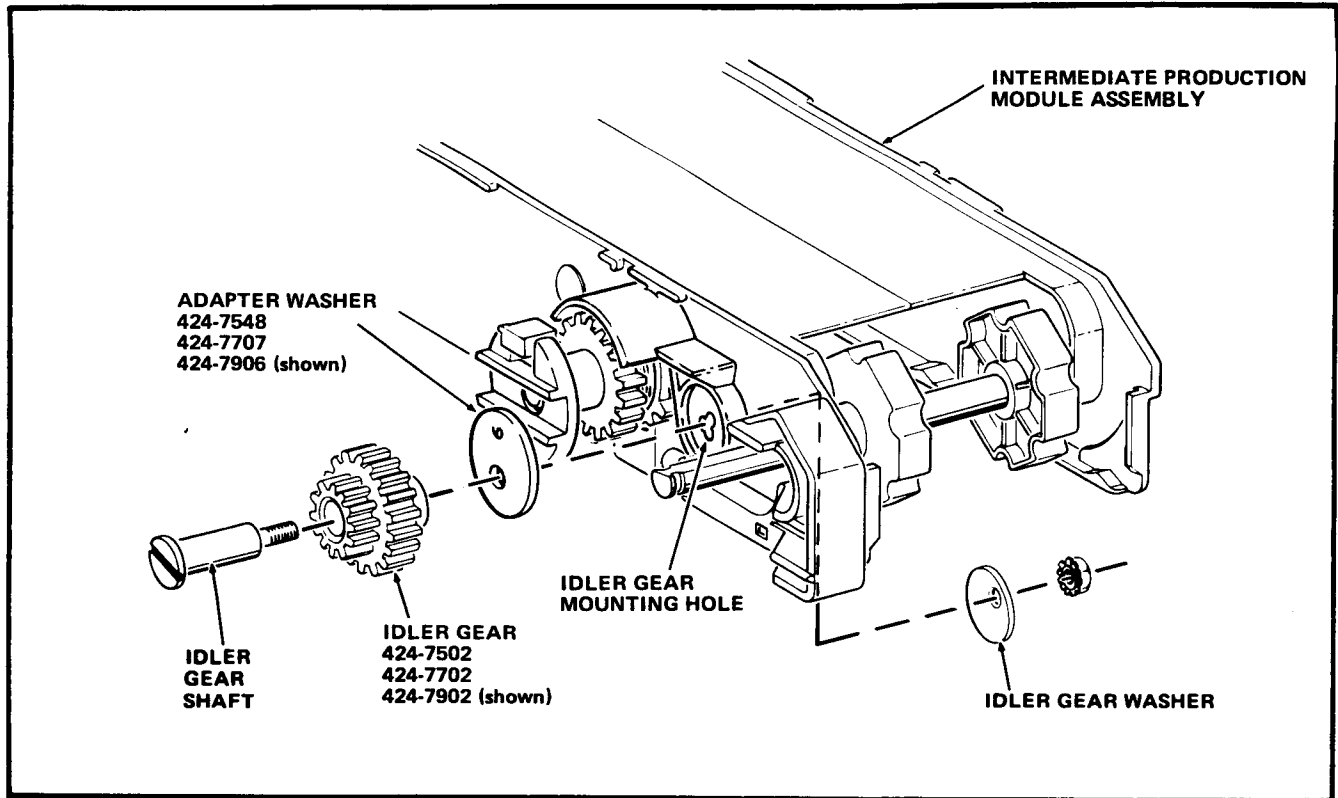
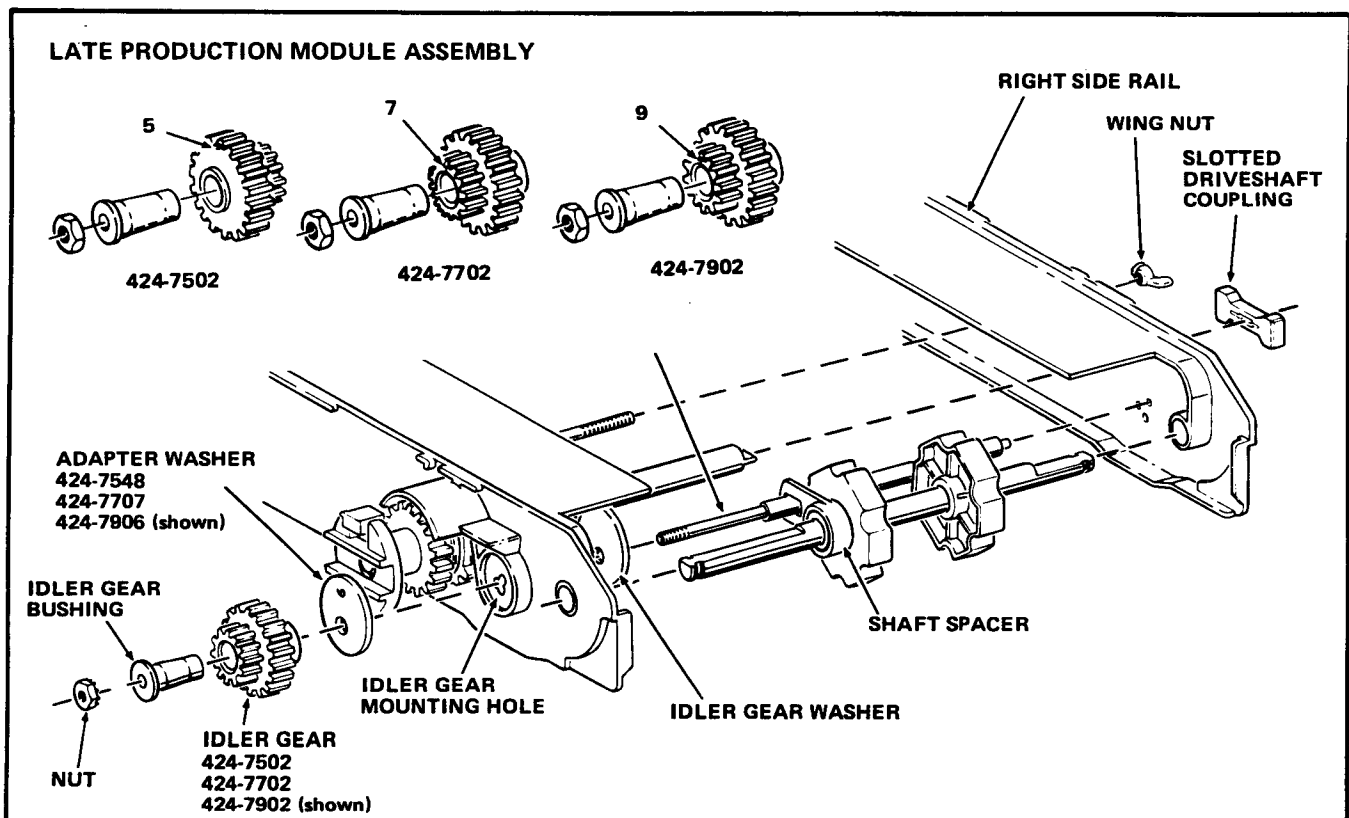

FIGURE 4



**FIGURE 5**



**FIGURE 6**

**CAUTION**

To avoid binding of the Idler Gear, tighten but do not over-torque the attaching Nut when performing Step B-5.

5. Install on the Idler Gear Shaft the replacement Idler Gear and Adapter Washer included in the kit, along with the Idler Gear Bushing and attaching Nut removed in Step A-11. See Figure 6.
6. Position the Right Side Rail removed in Step A-13 so that the unthreaded end of the Idler Gear Shaft is inserted through the hole in the Right Side Rail which corresponds to the selected position of the three-position mounting hole. See Figure 6.
7. Install the three Wing Nuts removed in Step A-13 on the three Carriage Bolts to attach Rails together. Make sure that the Rear Shaft, Drive Shaft and Forward Sprocket Shaft are properly positioned. If the Module Assembly was equipped with a Rear Blocker, be sure to install Rear Blocker. See Figure 6.
8. Install the Slotted Driveshaft Coupling removed in Step A-12. See Figure 6.

**NOTE**

When performing Step B-9 use the Belt Dividers provided in the kit (if converting to a 7 or 9 Count Module) and those removed in Step A-8. The 5 Count Module requires 10 Belt Dividers; the 7 Count Module requires 15; the 9 Count Module requires 20.

9. Install the Belt Dividers in the replacement Belt Assembly included in the kit, inserting the Belt Divider Prongs into the Belt Rib Holes. The Belt Dividers should fold back, toward the end of the Belt Assembly terminating in Tabs and away from the end terminating in Pockets. See Figure 7.

**NOTE**

Step B-10 should be performed only if a 5 Count Module is being converted to a 7 or 9 Count Module. The Rear Blocker is not used in the 5 Count Module.

10. Install the Rear Blocker, part number 424-7704, included in the Kit into the Module Assembly:
  - a. Loosen the Wing Nut attached to the Carriage Bolt at the rear of the Module Assembly. See Figure 8.

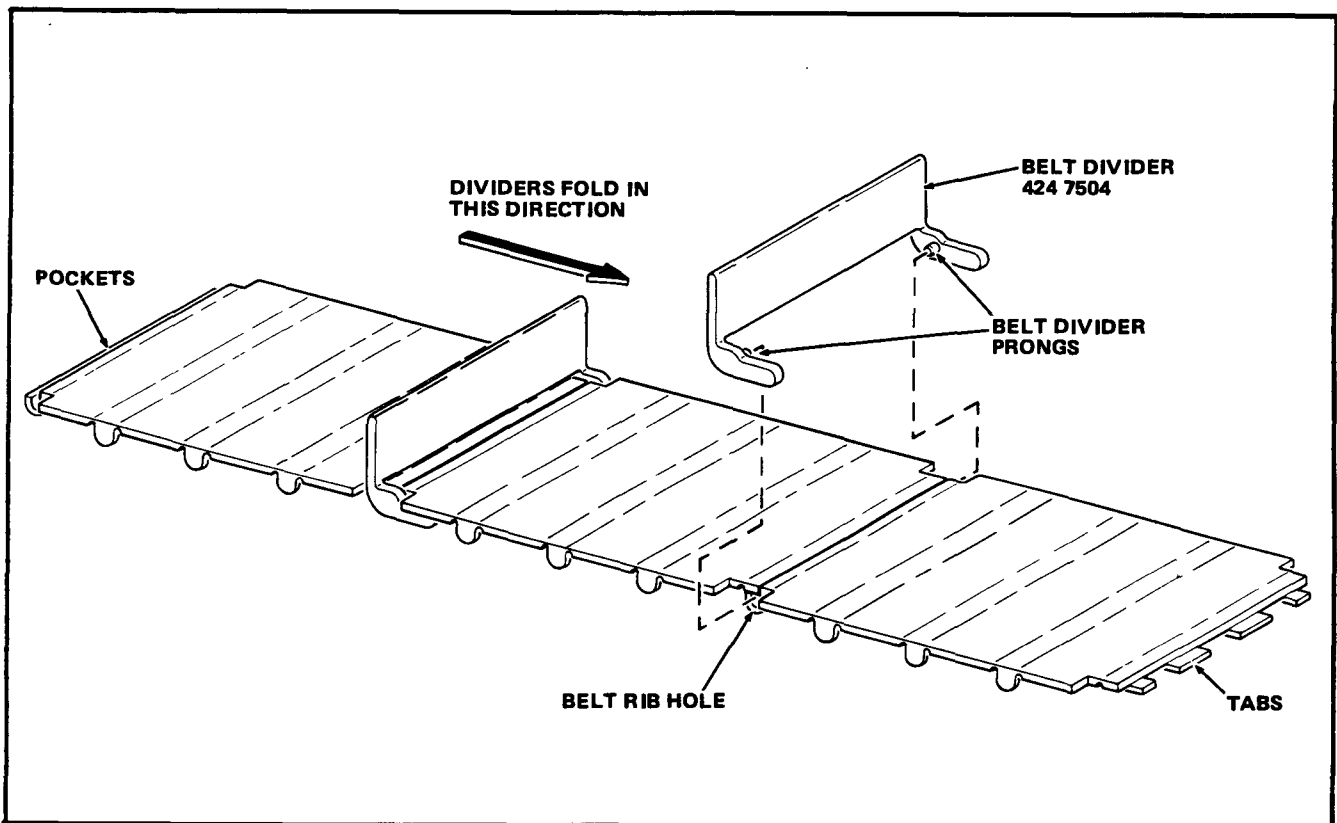

**FIGURE 7**

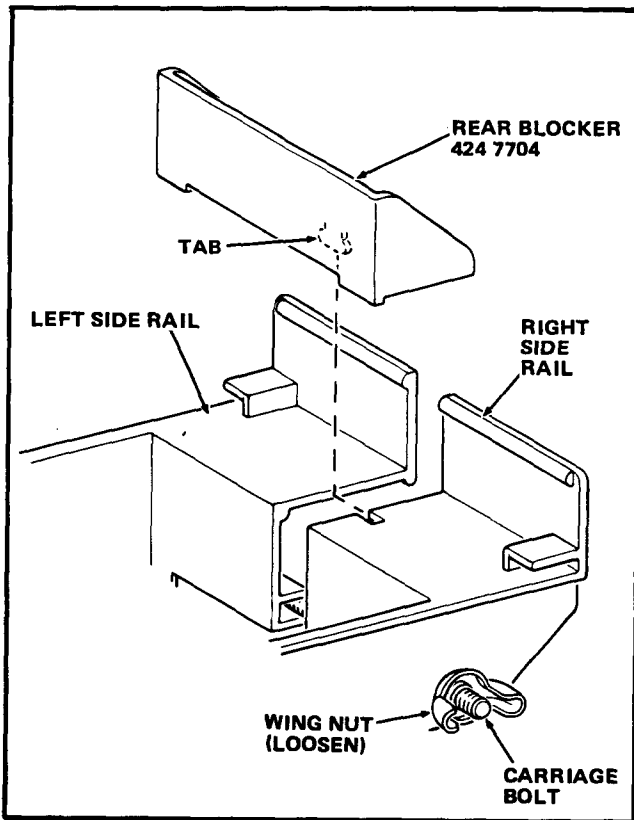

FIGURE 8

- b. Pull the Left and Right Rails of the Module Assembly apart and insert the Tab of the Rear Blocker into the Slot between the two Rails. See Figure 8.
- c. Tighten the Wing Nut. See Figure 8.
11. Lay the Product Belt on the top of the Module so that the Belt Divider will fold back, not forward. See Figure 9.
12. Turn the Front Sprocket Shaft so that its Flat side is facing straight up. See Figure 9.
13. Place the First Rib on the Belt into the top dwell position on the Front Sprockets. See Figure 9.
14. Holding the Belt in place on the Front Sprockets, stand the Module on its rear end and carefully thread the Belt through the front of the Module. See Figure 10.
15. Pull the Belt through the Module until it reaches the Rear Rollers. See Figure 10.
16. Lay the Module down and pull the Belt around the back of the Rear Rollers until about 15 cm (6 in.) of the Belt protrudes from the top of the Module. See Figure 11.

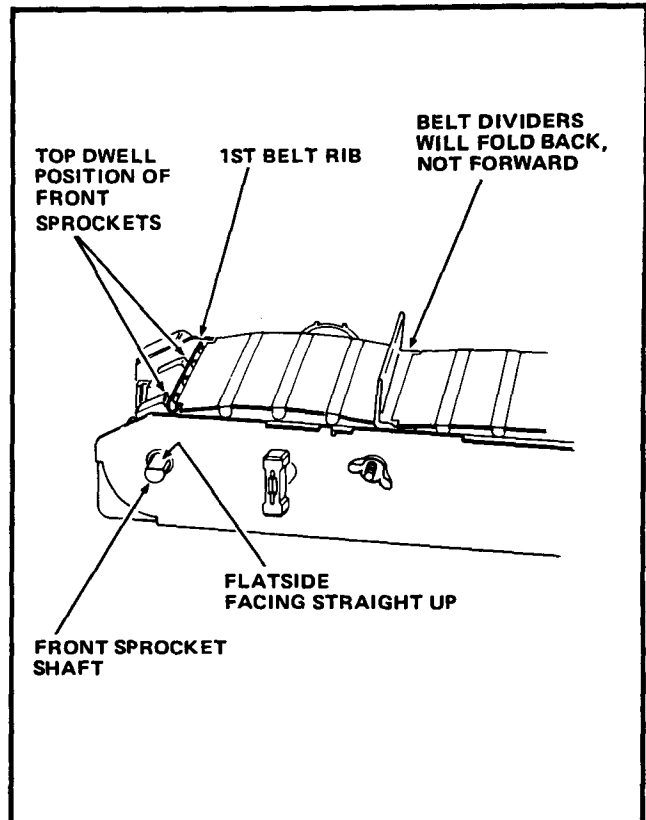

FIGURE 9

17. Move the Rear Shaft to its Forward limit. See Figure 11.
18. Align the Rear Rollers so that the Right Rear Roller is positioned between the Guide Tabs on the Belt. See Figure 11.
19. Grasp both ends of the Belt and pull them together. See Figure 12.
20. Insert the Tabs on the Front section of the Belt into the Pockets on the rear section of the Belt and snap the Belt together. See Figure 12.
21. Compress both of the Rear Spring Loads and place them in the Grooves on the Rear Shaft. See Figure 13.

**CAUTION**

Always pull the Product Belts in a Forward direction; on the top side, from the rear of the Module to the Front.

Never pull the Belts backwards; from the front of the Module to the rear. Pulling the Belts backwards can break the Belt Dividers.

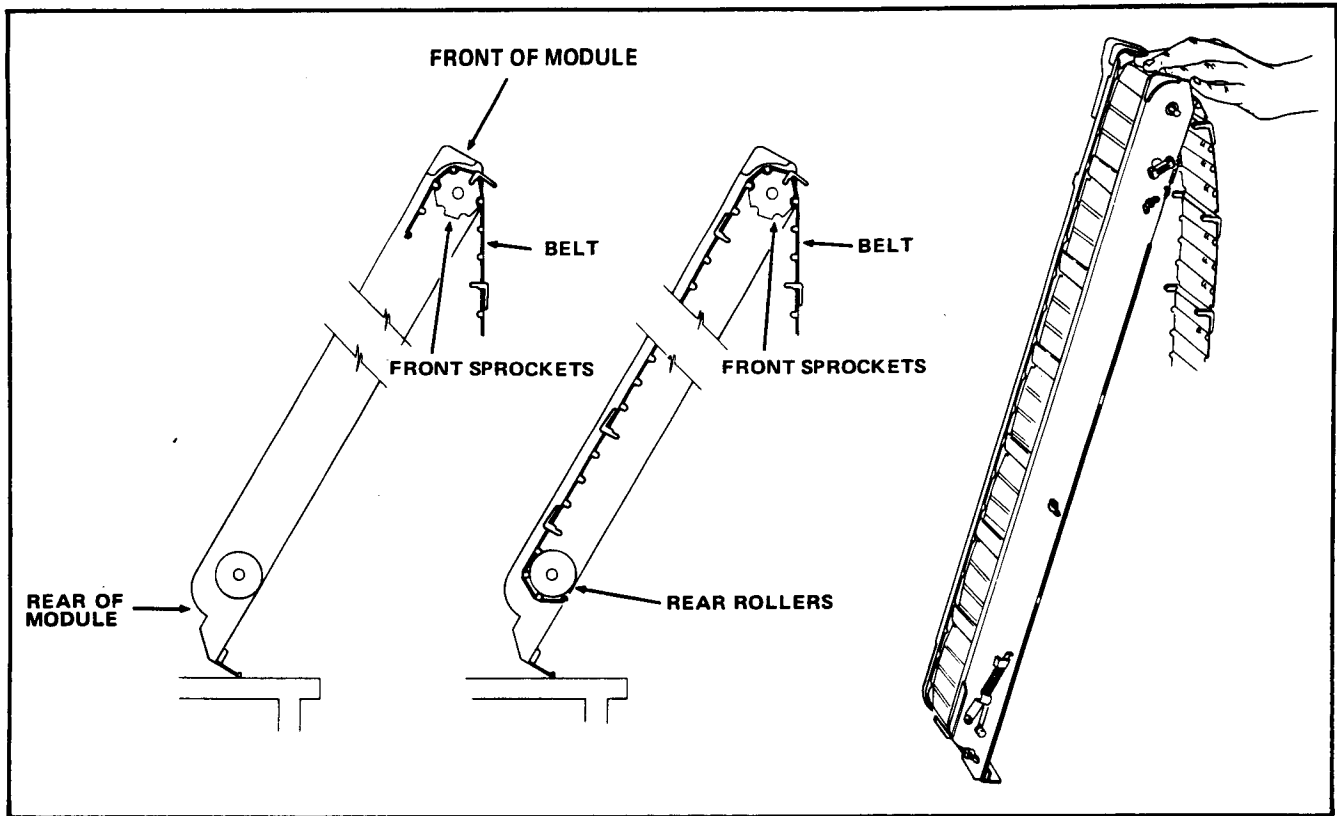

FIGURE 10

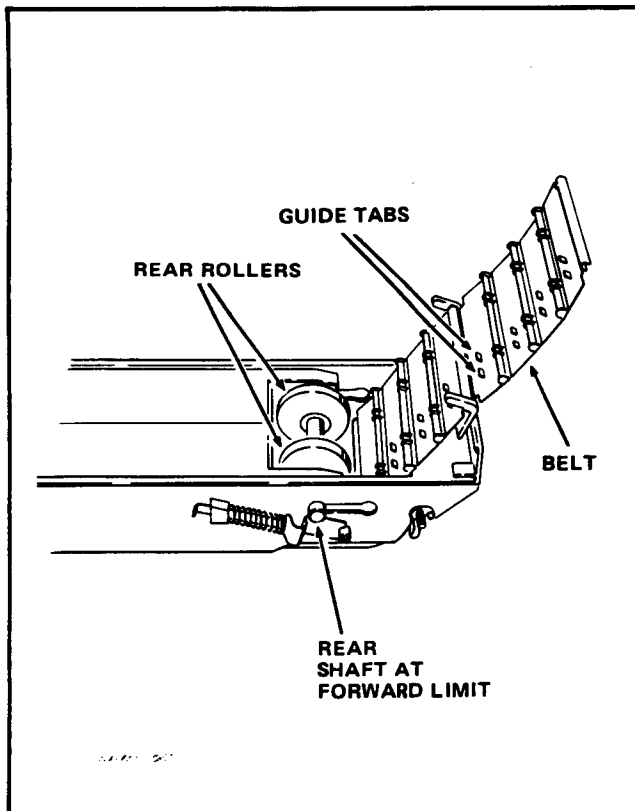

FIGURE 11

22. Install one Belt Divider into the vacant Belt Rib on the Product Belt and rotate the Belt one complete revolution to check for smooth operation.
23. Rotate the Belt Forward until the Flat side of the Front Sprocket Shaft faces straight up and a Belt Divider is positioned as shown in Figure 14.
24. Rotate the Drive Gear in either direction until it locks. See Figure 14.
25. Slide the Forward Sprocket Gear onto the Front Sprocket Shaft. It may be necessary to rotate the Gear until it will slide on; the Gear will go on in only one position. DO NOT rotate the Front Sprocket Shaft while installing the Forward Sprocket Gear. See Figure 14.



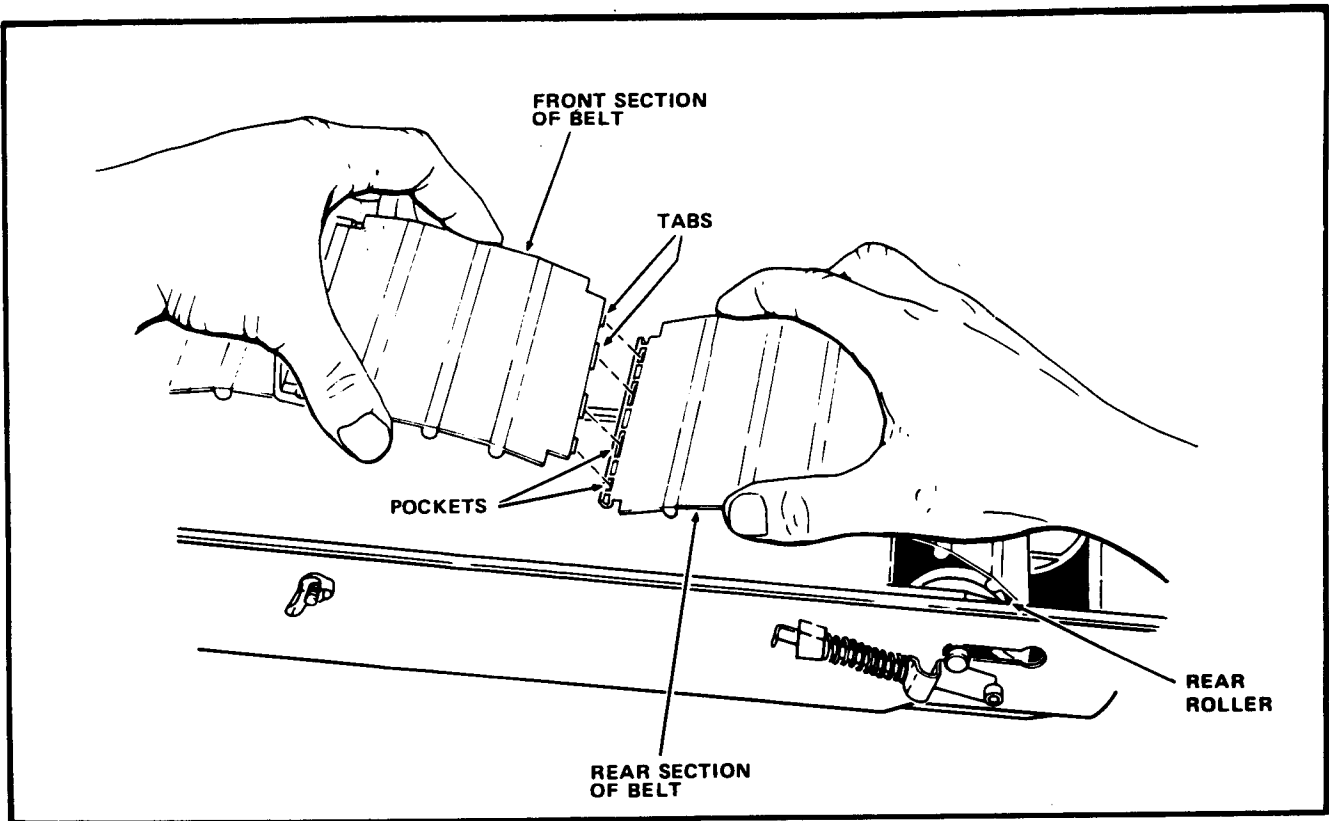

FIGURE 12

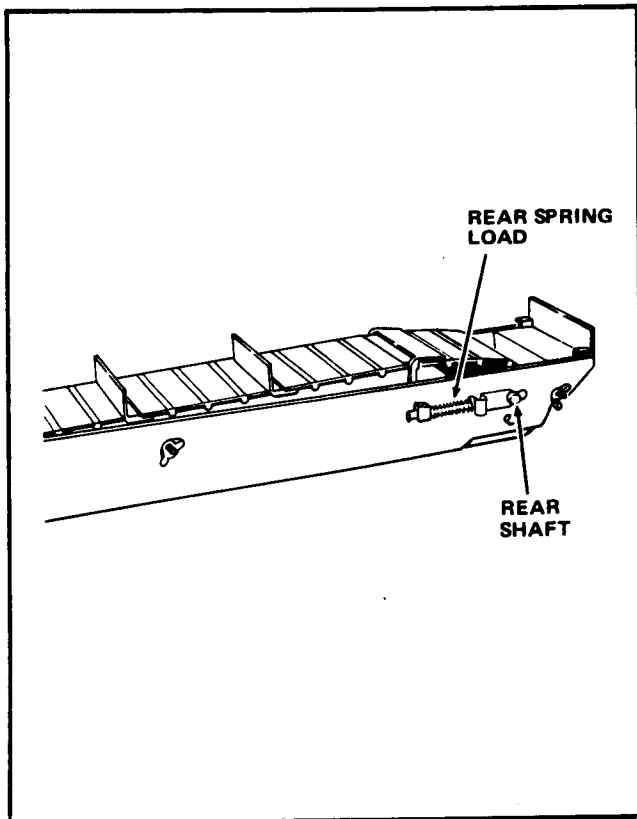

FIGURE 13

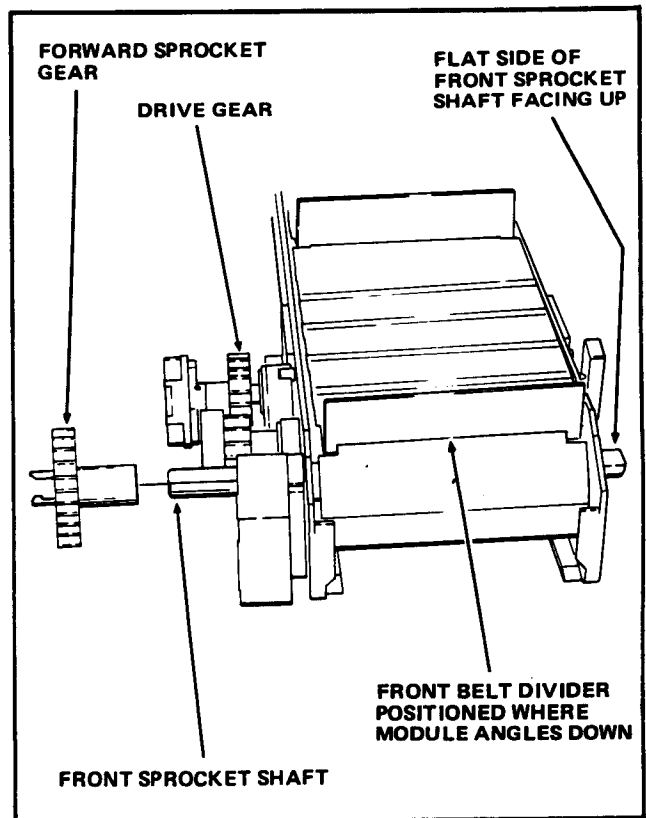

FIGURE 14